



SL80

3636

Landoll SwingMast

90°

SwingMast

2727

72

Curtis SEPEX
Curtis Series

762

76

1016

1066

Anderson SBX350

ANSI B56.1

()

-29°



« - »

115516, . , . 62

: (495) 730 95 88

www.kslift.ru e-mail: info@kslift.ru

LANDOLL CORPORATION

MATERIAL HANDLING PRODUCT DIVISION

WWW.LANDOLL.COM/MHP



			SL80
			3636
			600
			9500
		/	11,1
		/	12,3
		/	16,7
		/	21,3
		/	28,9
		/	18,2
		/	3/4
	a	3-	607
	b		1422
	c	3-	2769
	d		102
	e		889
	f		1321
	g		2286
	h		1422
	l		762
	j		76
	k		1321
	l		686
	m		1041
	n		2451
			1016
		%	15
			17,6
			6,5
		2	7,5 x 2
		()	/ 20x9/508x229
		()	/ 16.25x7/413x178
		72	53-55
			4,300/1,955
			Curtis Series

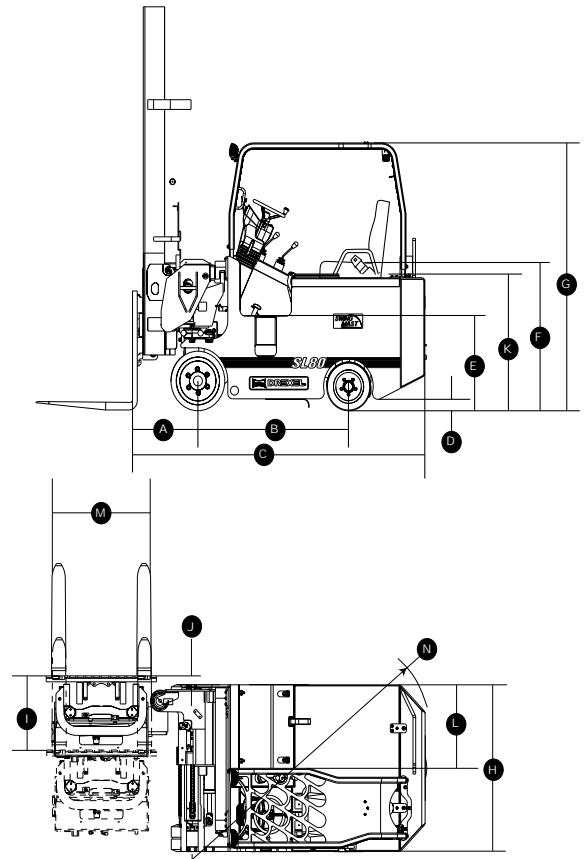

*		
	M	M
3.58	2.16	1.09
4.04	2.31	1.24
4.50	2.46	1.40
5.00	2.64	1.57
5.59	2.84	1.78
6.22	3.07	2.01
6.58	3.20	2.13
7.14	3.40	2.34
*	1067	

: 36-85-19, 72 , 765 / (6)
: 1955 - : 2136
: SBX 350
: 98 x 113 x 58
: 100 x 114 x 60



: (495) 730 95 88

: (495) 325 58 15 www.kslift.ru e-mail: info@kslift.ru

