



BENDI B40AC

AST-1778

Bendi B40AC –

25% *



1818

9,14

AST 1778

180°

1778

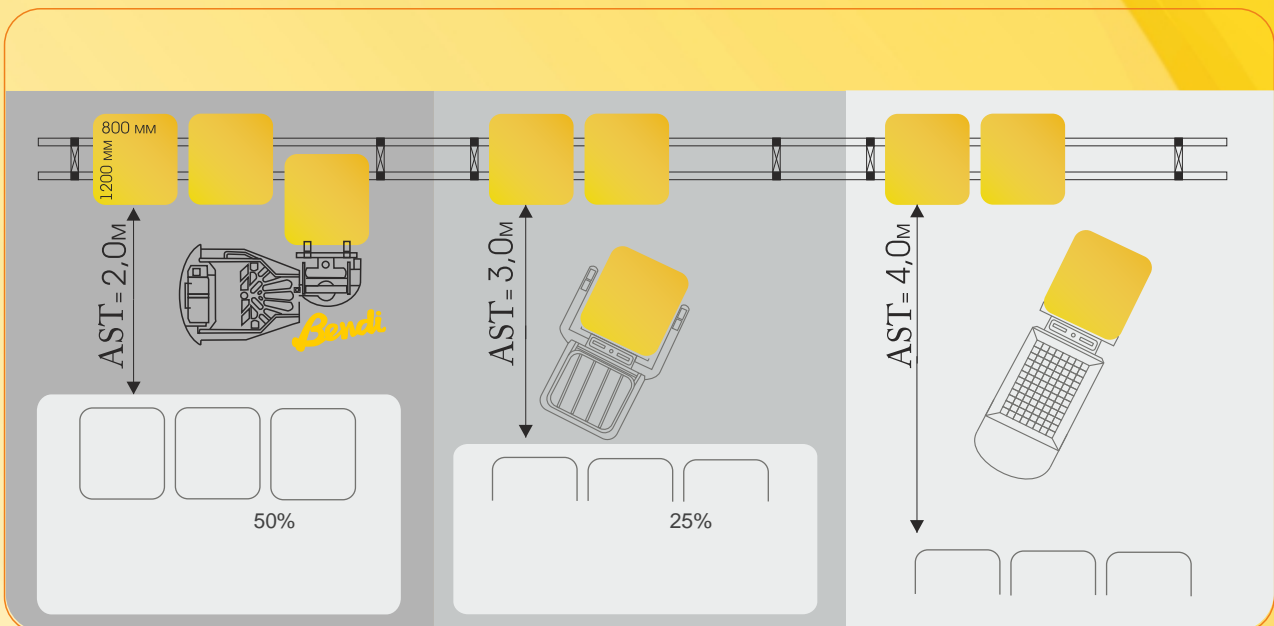

				B40AC
				1818
				600
				6259
		/		9,7
		/		10,5
		/		21
		/		27
		/		27
		/		18
		/	.	3/3 7,01
		/	.	1/3 7,01
	a			310
	b			1600
	c			2620
	d			76
	e			700
	f			1295
	g			2209
	h			1219
		%		15
		%		15
				11
				4,2
				6 , 12
				14 5
				18 7
				AC
	m			180

3-

M.	M.	M.
4.78	2.11	1.55
5.03	2.21	1.65
5.49	2.41	1.85
5.69	2.49	1.88
6.10	2.69	2.08
6.55	2.92	2.31
7.01	3.10	2.49
7.47	3.25	2.64
7.92	3.35	2.74
8.18	3.48	2.87
9.14	3.96	3.35

4-

6.35	2.21	1.57
7.01	2.41	1.78
7.47	2.57	1.93
7.92	2.72	2.08

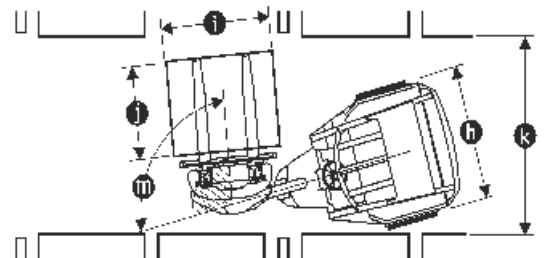
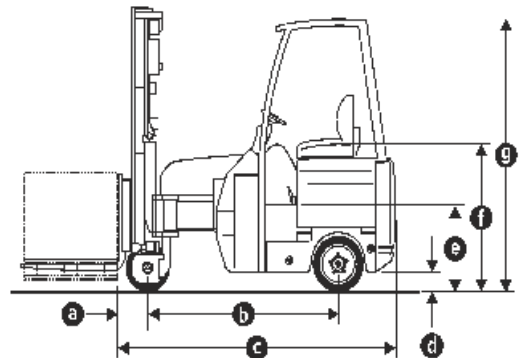

AST

(j x i)	(k)
1000 x 1200	1778
1200 x 1000	1981
	2743

: . 1181 - . - 1409
: SB 350
: 24-85-17, 48 , 680 / (6 .)
: 69 x 98 x 58
: 70 x 98 x 58
: 24-85-19, 48 , 765 / (6 .)
: 66 x 113 x 58
: 66 x 114 x 58

